

# Towards Distributed Mathematical Knowledge Management

Vyacheslav Zholudev

Jacobs University, Bremen

KWARC – Knowledge Adaptation and Reasoning for Content

April 3, 2008

- A lot of digital mathematical knowledge is available in the internet
- A lot of possibilities to communicate via internet
- Inefficient collaboration between the mathematicians

**Surface web**: static pages

**Deep web**: data are stored in the databases

- Searching
- Generation of documents on the fly
- Presentational documents
- Adaptation to different communities
- Multilingual documents

## Deep web:

- Searching

### Math Web Search A SEMANTIC SEARCH ENGINE

Search for: XML Query String

MathML XML

OpenMath XML

```

<mq:query xmlns:mq="http://mathweb.org/MathQuery">
  <math xmlns="http://www.w3.org/1998/Math/MathML">
    <apply><int/>
      <domainofapplication mq:generic="domain"/>
      <bvar> <ci>t</ci> </bvar>
      <apply><power/>
        <apply><ci mq:generic="fun"/>
          <ci>t</ci></apply>
          <cn mq:generic="pow">2</cn>
        </apply>
      </apply>
    </math>
  </mq:query>
  
```

[Examples](#) | [Querying](#) | [API](#) | [About](#) | [Contact](#) Search

## Deep web:

- Generation of documents on the fly

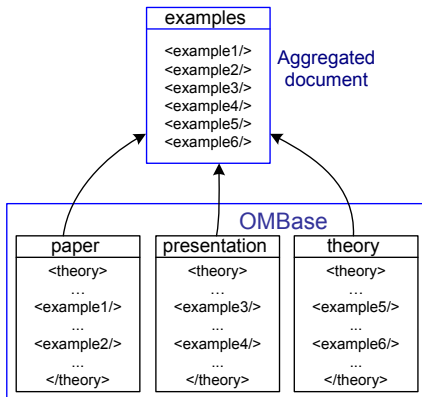

## Deep web:

### ● Presentational documents

The screenshot shows a web browser displaying a document titled "Monoid" on the SWIM (Semantic Web Information Management) platform. The document is written by Christoph Lange, dated 2006-06-09, and describes the definition of a monoid with its axioms.

**Monoid**

Written by: Christoph Lange  
Date: 2006-06-09  
Description: Definition of a monoid with its axioms

**AXIOM:**  
There is a right unit element in  $M$ .  
 $\exists x(x \in M) \wedge \forall y(y \in M \Rightarrow y \cdot x = y)$

**CONJECTURE:**  
There is exactly one right unit element in  $M$ .  
 $\exists x(x \in M) \wedge \forall y(y \in M \Rightarrow y \cdot x = y)$

**CONCEPT: unit**  
The unit element  $e$

**DEFINITION:**  
The unit element  $e$  is defined as the only element  $x$  in  $M$  with unit property.  
 $\forall y(y \in M \Rightarrow y \cdot e = y)$

**CONJECTURE:**  
The unit element  $e$  is also a left unit element on  $M$ .  
 $\forall x(x \in M \Rightarrow e \cdot x = x)$

**CONCEPT: setstar**  
The star operator for sets

**DEFINITION:**  
The star operator excludes the unit element  $e$  from any subset of  $M$ .  
 $\forall S(S \subseteq M \Rightarrow S^* = S \setminus \{e\})$

The interface includes navigation, edit, and search options. The left sidebar contains navigation links (Main Page, Related Pages, Recent Changes, Help) and edit options (New Resource, New Class, New Property, New Image). The bottom left shows a search bar and a history list. The right sidebar contains outgoing and incoming links.

## Deep web:

- Adaptation to the different communities
- Multilingual documents

Paper Output	Presentation Output
$\sum_{k=1}^n$	$\sum_{x=1}^n x$
$\bigcup_{k=1}^n$	$\bigcup_{k=1}^n$

- OMDoc [Koh06] - an open markup format for mathematical documents
- A number of applications that use OMDoc as a basis (Panta Rhei [Mül07], SWiM [Lan08], ActiveMath [Act07], etc.)
- File systems or versioning control systems are insufficient

- Markup all mathematics
- Content-oriented language
- Include OpenMath [BCC<sup>+</sup>04] and MathML [ABC<sup>+</sup>07]
- Only a way to prove the concepts

- 1 Subversion - version control system [SVN07]
- 2 Berkeley DB XML - XML-native database [Ber07]

- Repository
- Working copies

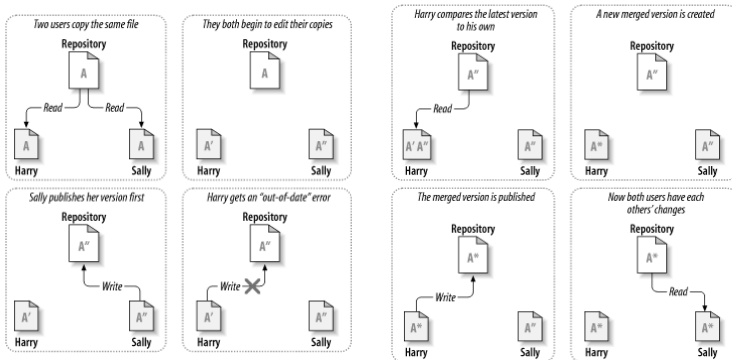
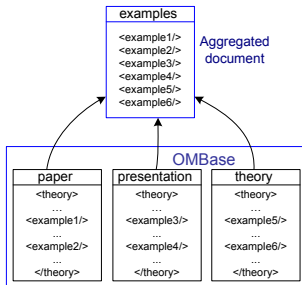

Figure: 1

Figure: 2

- 1 Facilitate the mathematicians' collaboration
- 2 Develop a more intelligent storage for OMDoc
- 3 Facilitate interoperation of math-specific applications
- 4 Get rid of a notion of files
- 5 Develop a high-level mathematical query language
- 6 Integrate with Management of Change systems



- 1 Retrieve aggregated documents
- 2 Support versioning: enhanced subversion
- 3 Distribution in OMBase (see next slide)
- 4 Obtain the presentation documents:
 
$$\binom{n}{k} \quad C_k^n \quad C_n^k$$
 - different notations for binomial coefficients

- Michael → Jacobs → Journal
- Normen updates from Michael → Normen updates from Jacobs

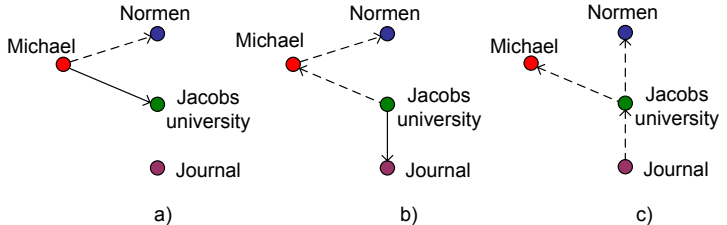



- XML-native database that supports versioning
- It constitutes the core of OMBase

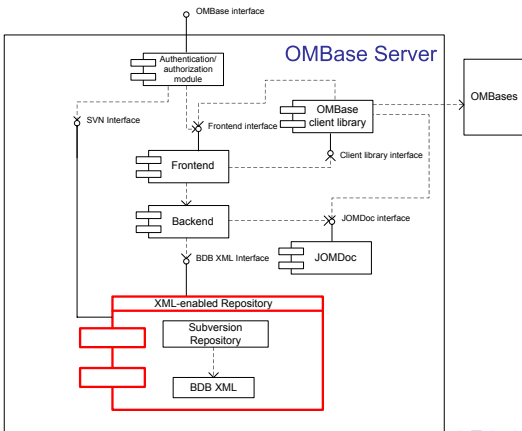

- Combination of Berkeley DB XML and Subversion
- Berkeley DB is an intersection

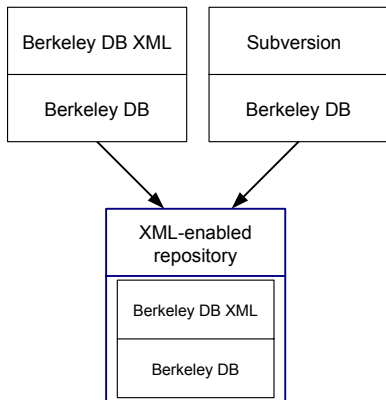

- OMBase can stand as a client for other OMBases
- Client library is responsible for this

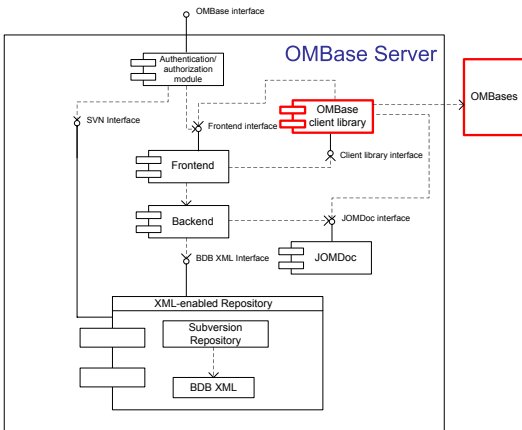

- Push and pull methods
- Movement of the original flag

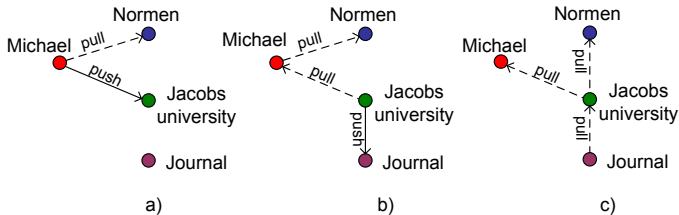

- Every application can access OMBase via HTTP
- *Standard client for OMBase* wraps HTTP-requests and manages versioning

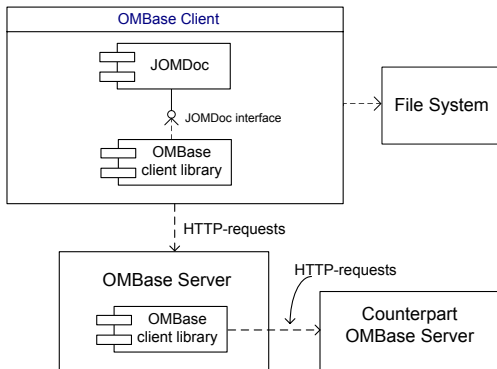

- The Connexions (CNX) system [CNX07]  
*Check the interface*
- The archive of scientific knowledge [ArX07]  
*Make a stress-testing*
- General Computer Science lectures at Jacobs  
university  
*Make my supervisor happy*

- The **mathematical-oriented storage for OMDoc** does not exist yet
- **The process** of creating such a storage is started
- **OMBase** should facilitate the process of creation math-orientated applications
- **OMBase** should enhance the collaboration between the mathematicians

## Deep web:

- Searching
- Generation of documents on the fly
- Presentational documents
- Adaptation  
to the different communities
- Multilingual documents



- Frontend parses the HTTP-requests
- Backend speaks to the XML-enabled repository

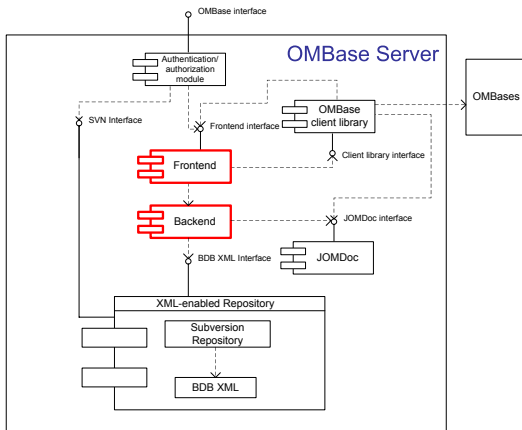



Ron Ausbrooks, Bert Bos, Olga Caprotti, David Carlisle, Giorgi Chavchanidze, Ananth Coorg, StÃ©phane Dalmas, Stan Devitt, Sam Dooley, Margaret Hinchcliffe, Patrick Ion, Michael Kohlhase, Azzeddine Lazrek, Dennis Leas, Paul Libbrecht, Manolis Mavrikis, Bruce Miller, Robert Miner, Murray Sargent, Kyle Siegrist, Neil Soiffer, Stephen Watt, and Mohamed Zergaoui.

Mathematical Markup Language (MathML) version 3.0.  
W3C working draft, World Wide Web Consortium, 2007.

Available at <http://www.w3.org/TR/MathML3>.



ACTIVEMATH, seen February 2007.

available at <http://www.activemath.org/>.



[arXiv.org](http://www.arxiv.org) e-Print archive, seen December 2007.  
web page at <http://www.arxiv.org>.



Stephen Buswell, Olga Caprotti, David P. Carlisle,  
Michael C. Dewar, Marc Gaetano, and Michael  
Kohlhase.

The Open Math standard, version 2.0.

Technical report, The Open Math Society, 2004.

<http://www.openmath.org/standard/om20>.



[Berkeley DB XML](http://www.oracle.com/database/berkeley-db/xml/index.html), seen December 2007.

available at <http://www.oracle.com/database/berkeley-db/xml/index.html>.



**CONNEXIONS.**

web page at <http://cnx.org>, seen January 2007.



Michael Kohlhase.

OMDoc – *An open markup format for mathematical documents [Version 1.2].*

Number 4180 in LNAI. Springer Verlag, 2006.



Christoph Lange.

SWIM: A semantic wiki for mathematical knowledge management.

web page at

<http://kwarc.info/projects/swim/>, seen  
February 2008.



Christine Müller.

Panta Rhei.

Project Home Page at

<http://kwarc.info/projects/panta-rhei/>,  
seen August 2007.



Subversion, seen May 2007.

available at <http://subversion.tigris.org/>.